

GENERAL INFORMATION



CAUTION: For your safety and to prevent damage to the machine, we recommend that you remove the line cord from the wall receptacle when setting or replacing the ribbon.

For repairs, please contact your authorized Acroprint dealer.

MAINTENANCE

To obtain the best results from your Time and Date Stamp, we recommend periodic inspections, cleaning, and lubrication each year by an authorized dealer. For further information contact your dealer or Acroprint Time Recorder. nationaltimestamp.com

NOTE: This equipment has been tested and found to comply with the limits for a Class A digital device, pursuant to Part 15 of the FCC Rules. These limits are designed to provide reasonable protection against harmful interference when the equipment is operated in a commercial environment. This equipment generates, uses, and can radiate radio frequency energy and, if not installed and used in accordance with the instruction manual, may cause harmful interference to radio communications. Operation of this equipment in a residential area is likely to cause harmful interference in which case the user will be required to correct the interference at his own expense.

MACHINE REFERENCE

Date Purchased _____
Model No. _____ Serial No. _____
Key No. _____
Dealer _____
Address _____
City _____ State _____ Zip _____
Phone No. _____



[Acroprint Time Stamp Service](#)

HEAVY-DUTY DOCUMENT CONTROL STAMP USER MANUAL



NATIONAL TIME STAMP
330-220-7655
nationaltimestamp.com
Acroprint ET Time Stamp
Machine

INTRODUCTION

We thank you for purchasing an Acroprint Date Time Stamp Machine. Packaged with your machine are:

- two (2) Keys.
- one (1) User's Manual and the Warranty Card.

Please complete the warranty card and return the tear-off portion to the factory as soon as possible. The model and serial numbers are displayed on the label located on the back of the time stamp. The serial number is a seven digit number followed by two alphabetic characters (example: 1234567AH).

We suggest you record the above information in the information reference section on the back page, making sure to list your key number.

Before operating your Acroprint Time and Date Stamp please read these instructions completely. For optimum performance, do not plug stamp into an electrical circuit with other office machines or appliances. Caution should be used when stamping forms with paper clips or staples attached. Serious damage to the print mechanism and/or the electronic circuit could result. Service should be limited to qualified technicians only.

FIGURE 2

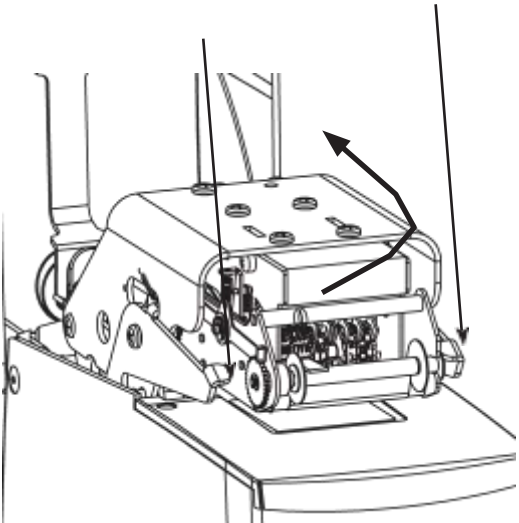

Depress to Raise Ribbon Feeler

Ribbon Drive Shaft

Apply pressure

Ribbon Tension Spring

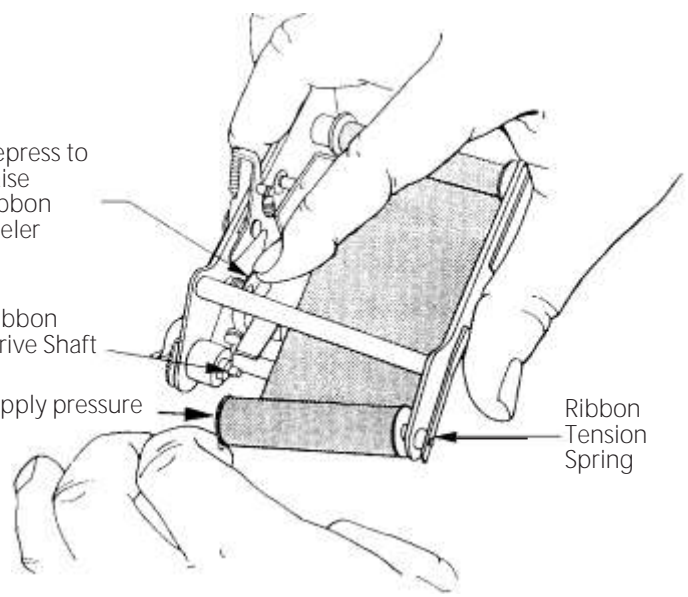
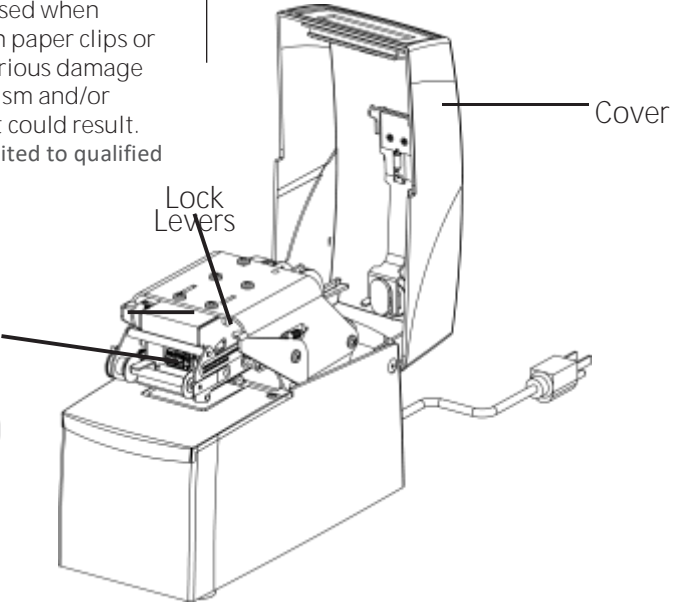
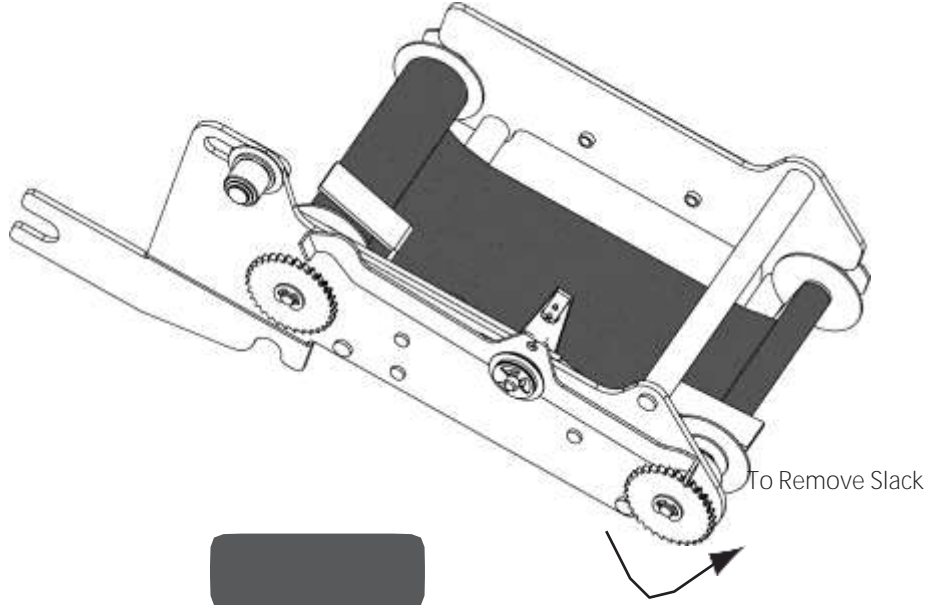

FIGURE 8



Cover

Lock Levers



To Remove Slack

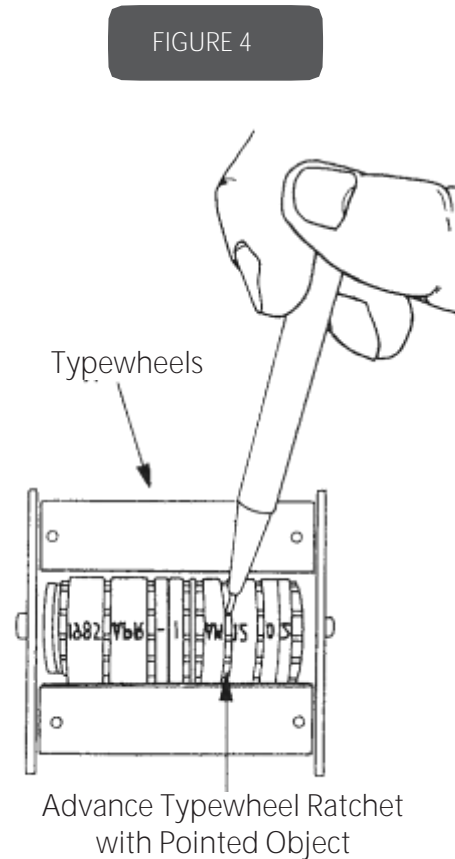
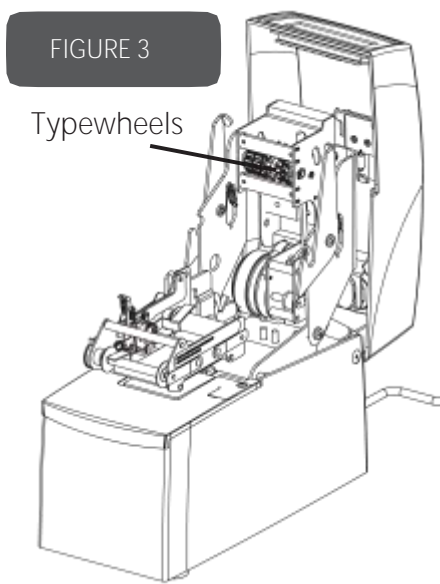
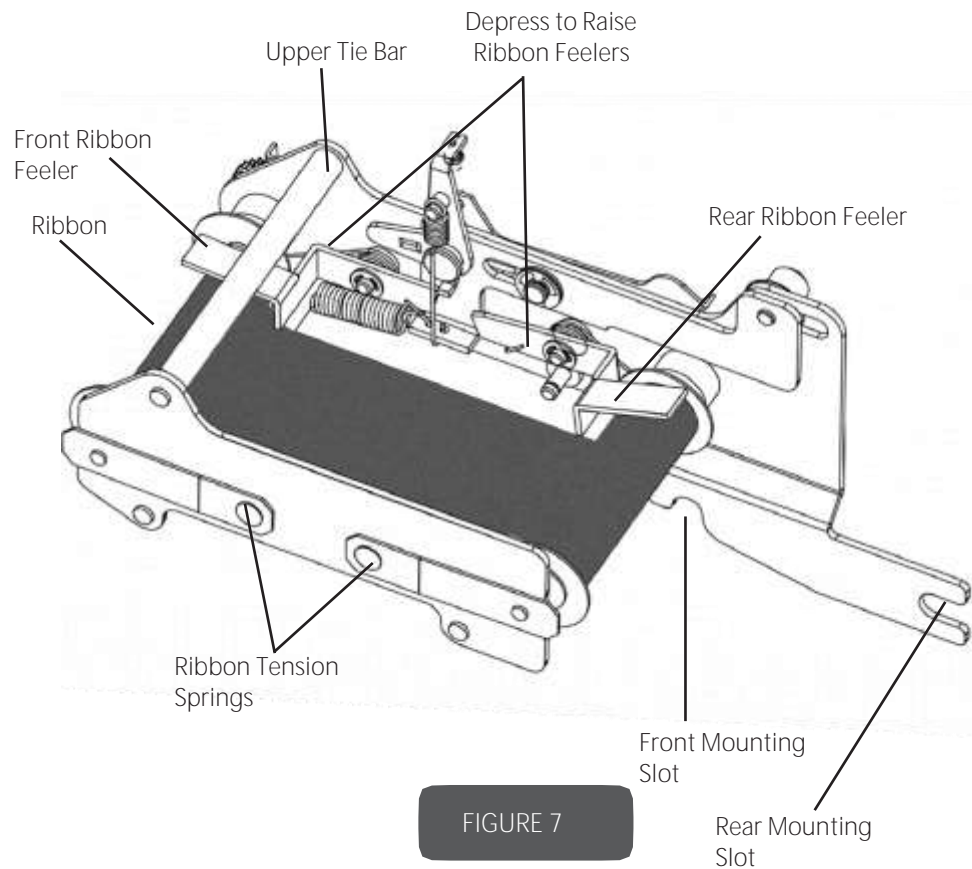
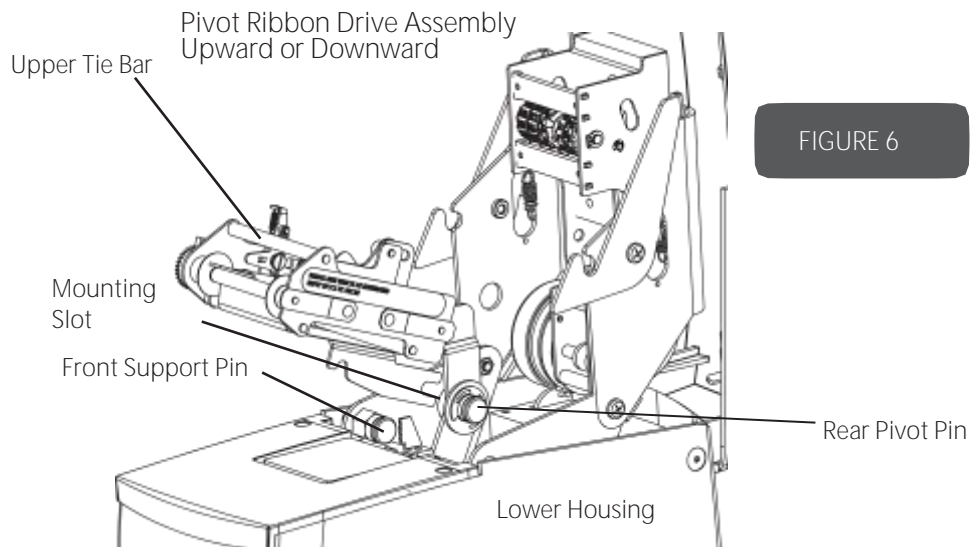

CAUTION:
Be sure the time clock machine is disconnected from the wall outlet when setting typewheels.



SETTING
The time stamp has a typehead with 6 or more typewheels which print information such as year, month, date, etc. It is necessary to set each typewheel prior to using your new machine.

Open Cover

- Insert key.
- Turn key clockwise and tilt cover upward.

Open Typehead

- Push down on the 2 lock levers, at the same time pull up on the typehead (See Figure 2).

Setting Typewheels

- Set the typewheels by pushing the Ratchet on the side of the typewheel down (See Figure 4). Make sure the typewheel seats correctly; you will hear a distinct click when the typewheel seats.

Model Notes:
Time/Date Stamps (ET and ETC) – After setting, the time stamp machine will keep the time and date automatically. The month typewheel must be manually changed and the date reset each month. The year typewheel must be manually changed each year.

Date Stamps (ED) – The date typewheels must be set each day.

Numbering Machines (EN, END, EDN) – The first 6 typewheels advance automatically after each punch. Any additional wheels (including date) must be manually changed.

ADJUSTABLE PRINT IMPACT CONTROL

The Time Stamp has an adjustable Print Impact Control (see Figure 5).

- Turning the knob clockwise increases the impact, turning the knob counterclockwise lowers the impact.

The standard setting is midway between soft and hard. Use the lowest setting that provides a clear imprint. Replacing worn ribbons instead of increasing the print impact will extend the machine's lifespan.

DIGITAL CLOCK - SETTING CONTROLS - ETC Model Only

The ETC Time Stamp is equipped with a digital clock. You will find the setting controls beside the Print Impact Control Knob located in the lower housing of the machine. (See Figure 5). Each control is labeled with letters and operates as follows.

Setting Function	Command
Hour Set:	Depress "H" switch
Minute Set:	Depress "M" switch

Setting Digital Display (ETC)

The digital display must be set to match the typewheels.

- Plug in machine.
- Press the H (Hour) button to advance the hour.
- Press the M (Minute) button to advance the minute.
- When you hear the minute advance click, take a print.
- Match the display to the printed time.

Close Typehead

- Lower the typehead.
- Press down and insure that both lock levers latch and typehead is secure.

Close Cover

- Lower the cover until it latches into the typehead assembly.

Digital Clock Controls
Adjustable Print Impact Control Knob

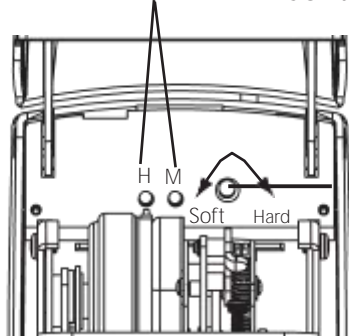

FIGURE 5

RIBBON REMOVAL/INSTALLATION

When the printing becomes light, change the ribbon. Using other than authorized Acroprint ribbons may result in the ribbon not advancing or reversing properly.

Warning

Be careful when changing the ribbon. Ribbon ink will stain your hands and clothes.

- 1 Unplug machine.
- 2 Open cover and type head.
(see Setting for instructions)
- 3 Grasp the Ribbon mechanism upper tie bar and pull upwards and then out.
- 4 Place the ribbon mechanism on a sheet of paper with the ribbon facing down.
- 5 Depress and hold down the front ribbon feeler lever. Push the back of the spool towards you until it clears the ribbon drive shaft, then pull the spool off of the ribbon tension spring.
(See Figure 8)
- 6 Repeat step 5 to remove the rear ribbon spool.
- 7 Place the new ribbon on a piece of paper with the spools about 6" apart and the empty spool at the front.
- 8 Place the ribbon drive mechanism over the ribbon.
- 9 Starting at the rear, pull the ribbon through the center and over the lower tie bar. Depress and hold down the rear ribbon feeler lever, with your other hand place the new spool on the stud on the ribbon tension spring. Apply pressure to the spool/spring, pivot the spool and mount the spool onto the ribbon drive shaft. Note: Rotate the spool to make sure it seats fully.

Warning: Be careful when changing the ribbon not to get ink on your clothing. The ink will not wash out of clothing.

- 10 Repeat step 9 to install the other spool on the front.
- 11 Remove ribbon slack by turning the front spool in the direction the arrow illustrates (See Figure 9). The ribbon is ready to be reinstalled.
- 12 Grasp the upper tie bar of the ribbon mechanism. Slide the rear mounting slot into the rear pivot pin (See Figures 6 & 7). Then pivot the ribbon mechanism down into front support pin slot.
- 13 Lower the typehead.
- 14 Close the cover.
- 15 Plug in machine and take a test print.